



Model 型号	EVE-INR18650/29V	Spec. No. 规格书编号	PBRI-INR18650/29V-D06-13	Version No. 版本	A
-------------	------------------	--------------------	--------------------------	-------------------	---

PRODUCT SPECIFICATION

产品交付规格书

Model (型号) : EVE-INR18650/29V

Designed 编制	RD Checked 产品设计审核	QC Checked 品质审核	Sales Checked 销售审核	Approved 批准
郑晓睿 2023.3.10	李跃飞 2023.3.10	李博 2023.3.20	马宝华 2023.03.20	宋明元 2023.3.23

Customer signature 客户接收栏
Company name: 公司名称:
Approved by: 批准:
Signature date: 日期:

February, 2023
EVE Energy Co., Ltd.

Model 型号	EVE-INR18650/29V	Spec. No. 规格书编号	PBRI-INR18650/29V-D06-13	Version No. 版本	A
-------------	------------------	--------------------	--------------------------	-------------------	---

Catalogue(目录)

1. Scope (适用范围)	1
2. Description and Model (基本信息)	1
3. Nominal Specifications (规格参数)	1
4. Outline Dimensions (外形尺寸)	2
5. Appearance (外观)	2
6. Standard Test Condition (标准测试条件)	2
6.1. Environment Condition (环境条件)	2
6.2. Measuring Equipment (测量设备)	2
7. Charging Method (充电方法)	3
7.1. Standard Charge (标准充电)	3
7.2. Rapid Charge (快速充电)	3
8. Electrical Characteristics (电性能)	3
8.1. Standard Discharge Capacity (标准放电容量)	3
8.2. Initial Internal Impedance (内阻)	3
8.3. Discharge Rate Capabilities (倍率放电性能)	4
8.4. Temperature Dependence of Discharge Capacity (不同温度放电性能)	4
8.5. Cycle Life (循环寿命)	4
8.6. Storage Characteristic (存储性能)	4

Model 型号	EVE-INR18650/29V	Spec. No. 规格书编号	PBRI-INR18650/29V-D06-13	Version No. 版本	A
-------------	------------------	--------------------	--------------------------	-------------------	---

9. Mechanical Characteristics (机械性能)	5
9.1. Free Fall Test (跌落测试)	5
9.2. Vibration Test (振动测试)	5
10. Safety (安全性能)	5
10.1. Overcharge Test (过充测试)	5
10.2. External Short-circuit Test (短路测试)	5
10.3. Forced Discharge Test (过放测试)	6
10.4. Heating Test (热冲击测试)	6
10.5. Low Pressure Test (低气压测试)	6
11. Status of the Cell as of Ex-factory (电芯出厂状态)	6
12. Warranty (质量保证)	6
13. Precautions and Safety Instructions (安全守则)	6
14. Guide for the use of Lithium-ion Cells (电芯使用指南)	7
14.1. General (总则)	7
14.2. Charging (充电)	7
14.3. Discharging (放电)	8
14.4. Storage (存储)	8
14.5. Cycle Life (循环寿命)	9
14.6. Design of System (系统设计)	9
14.7. Battery Pack Assembly (电池包装)	10



Model 型号	EVE-INR18650/29V	Spec. No. 规格书编号	PBRI-INR18650/29V-D06-13	Version No. 版本	A
-------------	------------------	--------------------	--------------------------	-------------------	---

14.8. Others (其他) 10

15. Others (其他) 12

15.1. Storage for a Long Time (长期存放) 12

15.2. Others (其他) 13

16. Consultation (联系方式) 13

Model	EVE-INR18650/29V	Spec. No.	PBRI-INR18650/29V-D06-13	Version No.	A
-------	------------------	-----------	--------------------------	-------------	---

1. Scope (适用范围)

This product specification has been prepared to specify the rechargeable lithium-ion cell to be supplied to customer by EVE Energy CO., LTD.

本产品规格书适用于由惠州亿纬锂能股份有限公司生产的锂离子电芯。

2. Description and Model (基本信息)

2.1 Description (描述) Lithium-ion rechargeable cell (锂离子电芯)

2.2 Model name (型号) EVE-INR18650/29V

3. Nominal Specifications (规格参数)

Item 项目	Specification 标准
3.1 Nominal Discharge Capacity 标称容量	2850mAh Charge: 0.56A, 4.20V, CCCV 56mA cut-off 充电: 0.56A 恒流充电至 4.20V, 恒压充电截止电流 56mA Discharge: 0.56A, 2.50V DC cut-off 放电: 0.56A 恒流放电至 2.50V 截止
3.2 Minimum Discharge Capacity 最小放电容量	2800mAh Charge: 0.56A, 4.20V, CCCV 56mA cut-off 充电: 0.56A 恒流充电至 4.20V, 恒压充电截止电流 56mA Discharge: 0.56A, 2.50V DC cut-off 放电: 0.56A 恒流放电至 2.50V 截止
3.3 Nominal Voltage 标称电压	3.60V
3.4 Standard Charge 标准充电	CCCV, 0.56A, 4.20±0.05V, 56mA cut-off 0.56A 恒流充电至 4.20±0.05V, 恒压充电截止电流 56mA
3.5 Rapid Charge 快速充电	CCCV, 1.4A, 4.20±0.05V, 140mA cut-off 1.4A 恒流充电至 4.20±0.05V, 恒压充电截止电流 140mA
3.6 Standard Discharge 标准放电	DC, 0.56A, 2.50V cut-off 0.56A 恒流放电至 2.50V 截止
3.7 Max. Continuous Discharge Current 最大持续放电电流	DC, 8.4A, 2.50V cut-off 8.4A 恒流放电至 2.50V
3.8 Charge/Discharge Voltage Range 充电/放电电压区间	4.20~2.50V
3.9 Cell Weight 电池重量	46.5g Max 最大 46.5g

Model	EVE-INR18650/29V	Spec. No.	PBRI-INR18650/29V-D06-13	Version No.	A
3.10 Cell Dimensions 电芯尺寸	Height: 65.00±0.15mm 高度: 65.00±0.15mm Diameter: 18.35±0.10mm 直径: 18.35±0.10mm				
3.11 Operation Temperature (Cell Surface Temperature) 使用温度范围 (电芯表面温度)	Ambient Temperature			环境温度	
	Charge: 0 to 45 °C Discharge: -20 to 60°C			充电: 0 to 45 °C 放电: -20 to 60°C	
3.12 Storage Temperature (At Shipping SOC) 存储温度 (出货态 SOC)	1 year 1 年			-20~25°C	
	3 months 3 个月			-20~45°C	
3.12 Storage Temperature (At Shipping SOC) 存储温度 (出货态 SOC)	1 month 1 个月			-20~60°C	

4. Outline Dimensions (外形尺寸)

See the attachment (Fig. 1). (详见附图 1)

5. Appearance (外观)

There shall be no such defects as rust, discoloration, leakage which may adversely affect commercial value of the cell.

电芯不能有生锈、变色、漏液等可能对电芯产生不利影响的缺陷。

6. Standard Test Condition (标准测试条件)

6.1. Environment Condition (环境条件)

Unless otherwise specified, all tests stated in this specification are conducted at temperature 25±2°C and humidity under 65% RH.

若无特别要求，此规格书上的产品测试条件均为温度：25±2°C，湿度：<65% RH。

6.2. Measuring Equipment (测量设备)

(1) Amp-meter and Volt-meter (电流表和电压表)

The amp-meter and volt-meter should have an accuracy of the grade 0.5mA and 0.5mV or higher.

电流表和电压表的精度应分别为 0.5mA 和 0.5mV 或以上。

(2) Slide Caliper (游标卡尺)

The slide caliper should have 0.01mm scale.

游标卡尺的测试精度应为 0.01mm。

Model	EVE-INR18650/29V	Spec. No.	PBRI-INR18650/29V-D06-13	Version No.	A
-------	------------------	-----------	--------------------------	-------------	---

(3) Impedance Meter (电压内阻测试仪)

The impedance meter with AC 1 KHz should be used.

使用频率为1KHz的电压内阻测试仪。

7. Charging Method (充电方法)

7.1. Standard Charge (标准充电)

Standard Charge means charging the cell CCCV with charge current 0.56A (0.2C), constant voltage 4.20V and 56mA cut-off in CV mode at 25±2°C for capacity.

标准充电即在环境温度为 25±2°C 的条件下, 先以恒定电流 0.56A (0.2C) 充电至 4.20V, 然后恒压充电至电流小于 56mA。

7.2. Rapid Charge (快速充电)

Rapid Charge means charging the cell CCCV with charge current 1.4A (0.5C), constant voltage 4.20V and 140mA cut-off in CV mode at 25±2°C.

快速充电即在环境温度为 25±2°C 的条件下, 先以恒定电流 1.4A (0.5C) 充电至 4.20V, 然后恒压充电至电流小于 140mA。

8. Electrical Characteristics (电性能)

Item 项目	Test Condition 测试条件	Criteria 检验标准
8.1. Standard Discharge Capacity (标准放电容量)	The Standard Discharge Capacity is the initial discharge capacity of the cell, which is measured with discharge current of 0.56A (0.2C) and cut-off voltage of 2.50V at 25°C after the standard charge. Referring IEC61960 Standard. 标准放电容量即电芯在 25°C 下按照标准充电方式充满电, 然后以 0.56A (0.2C) 放电至 2.50V 截止的容量。 (参考 IEC61960 标准)	Standard Discharge Capacity ≥ 2800mAh 标准放电容量 ≥ 2800mAh
8.2. Initial Internal Impedance (内阻)	Initial Internal Impedance is measured at AC 1KHz at shipping SOC. 使用频率为 AC 1KHz 的电压内阻测试仪测量出货态电芯的内阻。	Initial Internal Impedance ≤ 30mΩ 内阻 ≤ 30 mΩ

Model	EVE-INR18650/29V	Spec. No.	PBRI-INR18650/29V-D06-13	Version No.	A		
8.3. Discharge Rate Capabilities (倍率放电性能)	Discharge Capacity is measured with the various currents in the following table and 2.50V cut-off after the standard charge. 电芯按标准充电方式充电后, 以不同的放电电流恒流放电至 2.50V 截止电压。			Item 项目	Discharge Condition 放电条件		
				Current 电流 (A)	0.56	2.8	8.4
				Rate 倍率(C)	0.2	1.0	3.0
				Relative Capacity 相对容量(%)	100	≥90	≥90
8.4. Temperature Dependence of Discharge Capacity (不同温度放电性能)	Capacity comparison at each temperature, measured after storage at the test environment according to the below table with discharge constant current 0.56A (0.2C) and 2.50V cut-off after the standard charge at 25°C. 电芯在 25°C 环境下按标准充电方式充电后, 在不同温度搁置 3h 后以 0.56A (0.2C) 恒流放电至 2.50V 截止电压。			Item 项目	Discharge Temperature 放电温度		
				Temperature 温度(°C)	-20	25	55
				Storage Time 存储时间(h)	3	3	3
				Relative Capacity 相对容量(%)	≥70	100	≥90
8.5. Cycle Life (循环寿命)	Charge: rapid charge (1.4A, 4.20V, 140mA cut-off). Discharge: continuous discharge (2.8A, 3.00V cut-off). Rest time: 10min after charge and 30min after discharge. Capacity after 1000 cycles. 充电: 快速充电 (1.4A, 4.20V, 140mA 截止) 放电: 2.8A 放电, 3.00V 截止 搁置时间: 充电后搁置 10min, 放电后搁置 30min 循环 1000 次			Capacity ≥ 70% Ci Ci : the first discharge capacity of cycle life test at 25±2°C 1000 周循环容量 70%Ci Ci: 循环第 1 周的放电容量			
8.6. Storage Characteristic (存储性能)	Initial Capacity: Standard discharge capacity. Retention Capacity: The standard discharge capacity after fully standard charged storage at condition in the following table. Recovery Capacity: The standard discharge capacity of three times cycles after fully standard charged storage at condition in the following table. 初始容量: 标准放电容量 保持容量: 存储后, 标准放电容量 恢复容量: 存储后, 电芯充满电后标准放电容量 (循环 3 次)			Retention Ratio= Retention Capacity/ Initial Capacity*100% Recovery Ratio= Recovery Capacity/ Initial Capacity*100% 容量保持率=保持容量/初始容量*100% 容量恢复率=恢复容量/初始容量*100%			
				Item 项目	Retention Ratio 容量保持率	Recovery Ratio 容量恢复率	
				25°C 28Days 25°C 存储 28 天	≥85%	≥90%	
				55°C 7Days 55°C 存储 7 天	≥85%	≥90%	

Model	EVE-INR18650/29V	Spec. No.	PBRI-INR18650/29V-D06-13	Version No.	A
-------	------------------	-----------	--------------------------	-------------	---

9. Mechanical Characteristics (机械性能)

Item 项目	Test Method 测试方法	Criteria 检验标准
9.1. Free Fall Test (跌落测试)	<p>Each fully standard charged cell is dropped three times from a height of 1.0m onto a flat concrete floor at 20±5°C. The cells are dropped so as to obtain impacts in random orientations. After the test, the cells shall be put on rest for a minimum of 1h and then a visual inspection shall be performed.</p> <p>Free fall test is according to the IEC62133 standard.</p> <p>在 20±5°C 环境下, 充满电的电芯从 1.0m 的高度以随机的方向跌落至水泥地板 3 次, 实验后放置至少 1h 后进行外观检查。</p> <p>(跌落测试按照 IEC62133 标准进行)</p>	<p>No fire, no explosion.</p> <p>电芯不起火, 不爆炸</p>
9.2. Vibration Test (振动测试)	<p>For X and Y axis with cylindrical cell 7Hz→200Hz→7Hz for 15min, repetition 12 times totally 3 hours, the acceleration 1g during 7 to 18Hz, then amplitude 1.6mm and maximum 8g up to 200Hz. Tests are to be conducted at 20±5°C.</p> <p>Vibration test is according to the UN38.3 standard.</p> <p>在 20±5°C 下, 充满电的电芯固定在振动台上, 振动频率由 7Hz 增加到 200Hz 然后再降到 7Hz 的时间为 15 分钟, 重复 12 次, 总计 3h。从 7Hz 开始保持 1g 的加速度直到频率达到 18Hz, 保持 8g 的加速度 (振幅 1.6mm), 直到频率达到 200 Hz。</p> <p>(振动测试按照 UN38.3 标准进行)</p>	<p>No fire, no explosion, no leakage, with less than 10% of OCV drop.</p> <p>电芯不起火、不爆炸、不漏液, 电压下降小于 10%</p>

10. Safety (安全性能)

Item 项目	Test Condition 测试条件	Criteria 检验标准
10.1. Overcharge Test (过充测试)	<p>Fully standard discharged cell is charged with 5.6A to 8.4V or until charging time up to 24h.</p> <p>Overcharge test is according to the UN38.3 standards.</p> <p>先将电芯以标准放电方式放电至截止电压, 然后将电芯正负极连接于恒压电源, 对电芯以 5.6A 充电, 直到输出电压不低于 8.4V, 持续充电 24h 或电压不再增加。</p> <p>(过充测试按照 UN38.3 标准执行)</p>	<p>No fire, no explosion.</p> <p>电芯不起火, 不爆炸</p>
10.2. External Short-circuit Test (短路测试)	<p>Fully standard charged cell is to be short-circuited by connecting the positive and negative terminals of the cell with a circuit load having are resistance load of 80±20mΩ. Until the test time is lasting to 10min.</p> <p>External short-circuit test is according to the UL1642 standard.</p> <p>电芯按标准充电方式充满电后, 用一外部电阻 80±20mΩ 的导线连接电芯正负极端, 使其外部短路, 直到测试时间持续到 10min。</p> <p>(短路测试按照 UL1642 标准进行)</p>	<p>No fire, no explosion.</p> <p>电芯不起火, 不爆炸</p>

Model	EVE-INR18650/29V	Spec. No.	PBRI-INR18650/29V-D06-13	Version No.	A
10.3. Forced Discharge Test (过放测试)	<p>A discharged cell is subjected to a reverse charge at 2.8A (1C) for 90 min at 20±5°C. Forced discharge test is according to the IEC62133 standard.</p> <p>先将电芯以标准放电方式放电至截止电压，然后在 20±5°C下以 2.8A(1C)强制放电 90min。</p> <p>(过放测试按照 IEC62133 标准进行)</p>			<p>No fire, no explosion.</p> <p>电芯不起火，不爆炸</p>	
10.4. Heating Test (热冲击测试)	<p>To heat up the standard charged cell at heating rate 5°C per minute up to 130°C±2°C and keep the cell in oven for 10 minutes.</p> <p>Heating test is according to the UL1642 standard.</p> <p>将电芯放置于电热鼓风干燥箱中，以 5°C/min 的速率由室温升至 130°C±2°C 并保持 10min。</p> <p>(热冲击测试按照 UL1642 标准进行)</p>			<p>No fire, no explosion.</p> <p>电芯不起火，不爆炸</p>	
10.5. Low Pressure Test (低气压测试)	<p>Fully standard charged cell is to be stored at a pressure of 11.6 kPa or less for at least six hours at ambient temperature.</p> <p>Low pressure test is according to the UN38.3 standards.</p> <p>电芯按标准充电方式充电后，电芯在绝对压力为 11.6kPa，温度为室温条件下贮存 6 小时。</p> <p>(低气压测试按照 UN38.3 标准执行)</p>			<p>No fire, no explosion and no leakage with less than 10% of OCV drop.</p> <p>电芯不起火、不爆炸、不漏液，电压下降小于 10%</p>	

11. Status of the Cell as of Ex-factory (电芯出厂状态)

The cell should be shipped in 3.45V to 3.60V charging voltage range (20~30% SOC).
电芯应在 3.45V 至 3.60V (20~30%SOC) 范围内装运。

12. Warranty (质量保证)

The warranty period of cells are made according to business contract. However, even though the problem occurs within this period, EVE won't replace a new cell for free as long as the problem is not due to the failure of EVE manufacturing process or is due to customer's abuse or misuse.

自出货之日起，电芯的保质期限依合同而定。但是，在此期限内，如果非 EVE 的制程原因，而是客户的误用造成的电芯质量问题，EVE 不承诺免费更换。

EVE will not be responsible for trouble occurred by handling outside of the precautions in instructions.

EVE 对违反安全守则操作所产生的问题不承担任何责任。

EVE will not be responsible for trouble occurred by matching electric circuit, cell pack and charger.

EVE 对与电路、电池组、充电器搭配使用所产生的问题不承担任何责任。

EVE will be exempt from warrantee any defect cells during assembling after acceptance.

出货后客户在电芯组装过程中产生的不良电芯不在 EVE 质量保证的范围之列。

13. Precautions and Safety Instructions (安全守则)

亿纬保密信息，未经允许不得扩散

Model	EVE-INR18650/29V	Spec. No.	PBRI-INR18650/29V-D06-13	Version No.	A
-------	------------------	-----------	--------------------------	-------------	---

Lithium-ion rechargeable cells subject to abusive conditions can cause damage to the cell and/or personal injury. Please read and observe the standard cell precautions below before using utilization.

滥用锂离子充电电芯可能会造成电芯的损害和人身伤害。在使用锂离子充电电芯以前，请仔细阅读以下的安全守则。

Note 1. Customer shall contact EVE in advance if it intends to use the cell in applications or operating conditions other than those described in this document.

注释 1. 如果客户需要将电芯在此文件之外的条件下操作或应用，请先咨询 EVE 相关事宜。

Note 2. EVE will take no responsibility for any accident that occurs when the cell is used under conditions other than those described in this document.

注释 2. 在此文件说明的条件之外使用该电芯而产生的事故，EVE 不承担任何责任。

Note 3. For the sake of safety assurance, please discuss the equipment design, its system and protection circuit of Lithium-ion cell with EVE in advance, and consult about the high rate current, rapid charge and special application in the same way.

注释 3. 为了保证电芯在使用过程中的安全，请提前与 EVE 讨论锂离子电芯的电池包、系统及保护电路设置。大电流应用、快速充电及其他特殊用途同样需要提前与 EVE 讨论。

14. Guide for the use of Lithium-ion Cells (电芯使用指南)

14.1. General (总则)

This chapter has been prepared to describe the appropriate cautions and prohibitions, which the customer should take or employ when the customer uses and handles the lithium ion cell to be manufactured and supplied by EVE Energy CO., LTD., in order to obtain optimal performance and safety.

为了达到最佳的性能和保证电芯使用安全，此部分旨在介绍客户在使用和处理 EVE 制造和供应的锂离子电芯时应注意的事项和禁止事项。

14.2. Charging (充电)

14.2.1. Charging Current (充电电流)

Charging current shall be less than maximum charge current specified in the specification.

电芯应在规格书限定的充电电流范围内充电。

14.2.2. Charging Voltage (充电电压)

Charging shall be done by voltage less than that specified in the specification.

电芯充电电压不得超过规格书中限定的电压。

14.2.3. Charging Temperature (充电温度)

The cell shall be charged within a range of specified temperatures in the specification.

电芯应在规格书限定的充电温度范围内充电。

Model	EVE-INR18650/29V	Spec. No.	PBRI-INR18650/29V-D06-13	Version No.	A
-------	------------------	-----------	--------------------------	-------------	---

14.2.4. Reverse Charging (反向充电)

The cell shall be connected, confirming that its poles are correctly aligned. Inverse charging shall be strictly prohibited. If the cell is connected improperly, it may be damaged.

电芯充电连接时应保证正负极连接正确，严禁反向充电。如果电芯正负极连接错误，电芯可能损坏。

14.3. Discharging (放电)

14.3.1. Discharging Current (放电电流)

The cell shall be discharged continuously at less than maximum discharging current specified in the specification. In case of the higher discharging current should be set, it shall be discussed with EVE.

电芯应在规格书中限定的最大放电电流放电。如果需要设置更高的放电电流，请与 EVE 讨论。

14.3.2. Discharging Temperature (放电温度)

The cell shall be discharged within a range of temperatures specified in the specification. Otherwise, it may cause loss of performance characteristics.

电芯应在规格书规定的温度范围内放电。否则，可能会导致电芯性能的损失。

14.3.3. Over-discharging (过放电)

The system should equip with a device to prevent further discharging exceeding discharging cut-off voltage specified in the specification.

系统应配备保护板，防止进一步放电，避免电压低于规格书中规定的放电截止电压。

Over-discharging may cause loss of performance characteristics of cell. Over-discharging may occur by self-discharging if the cell is left for a very long time without any use.

过放电会导致电芯性能的损失。如果电芯放置很长一段时间不使用，电芯自放电可能会导致过放。

The charger should equip with a device to detect voltage of cell box and to determine recharging procedures.

充电器应配置保护板检测电池包电压和确定重新充电程序。

14.4. Storage (存储)

14.4.1. Storage Conditions (存储条件)

The cell should be stored within a range of temperatures specified in the specification. Otherwise, it may cause loss of performance characteristics, leakage and/or rust.

电芯应在规格书规定的温度范围内储存。否则，可能会导致电芯性能的损失，漏液或生锈。

14.4.2. Long Term Storage (长期存储)

The cell should be used within a short period after charging because long-term storage may cause loss of capacity by self-discharging. If long-term storage is necessary, the cell should be stored at lower voltage within a range specified in the specification, because storage with higher voltage may cause more loss of performance characteristics.

电芯充电后应在短时间内使用，因为长期储存可能会因自放电而导致容量损失。如果需要长期存储，电芯应

Model	EVE-INR18650/29V	Spec. No.	PBRI-INR18650/29V-D06-13	Version No.	A
-------	------------------	-----------	--------------------------	-------------	---

在规格书规定的范围内以较低的电压存储，因为高电压存储可能会导致电芯性能的损失。

14.5.Cycle Life (循环寿命)

The cell can be charged & discharged repeatedly up to times with a certain level of capacity specified in specification.

电芯可经历多次充放电循环，达到规格书中指定次数下规定的容量水平。

Cycle life may be determined by conditions of charging, discharging, operating temperature and/or storage.

充放电方式、电芯使用温度或存储条件可以会影响电芯的循环性能。

14.6.Design of System (系统设计)

14.6.1. Connection between the cell and the battery (电芯和电池间的连接)

The cell should not be soldered directly with other cells. Namely, the cell should be welded with leads on its connector and then be soldered with wire or leads to solder. Otherwise, it may cause damage of component, such as separator and insulator, by heat generation.

电芯不能与其他电芯直接焊接。电芯的连接片上应焊接引线，然后用导线或引线焊接到焊盘上。否则，电芯可能会产热导致隔膜和绝缘垫片损坏。

14.6.2. Positioning the Battery in the System (电芯的放置)

The battery should be positioned as possible as far from heat sources and high temperature components. Otherwise, it may cause loss of characteristics. The recommended spacing between the cells is more than 1mm.

电芯应尽可能远离热源和高温物体。否则，可能会导致电芯性能的损失。电芯之间的距离建议大于 1mm。

14.6.3. Mechanical Shock Protection of the Battery (电池组机械冲击保护)

The battery should be equipped with appropriate shock absorbers in the pack in order to minimize shock, which can damage the cells. Otherwise, it may cause shape distortion, leakage, heat generation and/or rupture and/or open circuit.

电池组应配备合适的减震器，以最大限度地减少震动，避免损坏电芯。否则可能导致电芯发生形变、泄漏、发热、破裂或断路。

14.6.4. Short-circuit Protection of the Cell (电芯短路保护)

The cell equips with an insulating sleeve to protect short-circuit which may occur during transportation, battery assembly and/or system operation. If the cell sleeve is damaged by some cause such as outside impact, it may cause short-circuit with some wiring inside the battery.

电芯带有绝缘套管，以避免电芯在运输、组装或系统运行过程中发生短路。如果电芯套管因外界撞击等原因损坏，可能会导致电池组内部的一些线路发生短路。

14.6.5. Connection between the Battery and Charger/System (电池组与充电器/系统之间的连接)

The battery should be designed to be connected only to the specified charger and system. A reverse connection of the battery, even in the specified system, should be avoided by employing special battery design such as a special

Model	EVE-INR18650/29V	Spec. No.	PBRI-INR18650/29V-D06-13	Version No.	A
-------	------------------	-----------	--------------------------	-------------	---

terminal.

电池组应设计为只能连接到特定充电器和系统。即使在指定的系统中，也应采用特殊的电池设计（如特殊的电池端子）来避免电池的反向连接。

14.6.6. Pack Design (电池包设计)

The system should be equipped with a device to monitor each voltage of cell block to avoid cell imbalance which can cause damage to the cells.

系统应配置设备监测每个电芯电压，避免电芯不平衡造成电池损坏。

The battery pack or system should have warning system such as over temperature, over voltage, over current, and so on.

电池组或系统应具有过热、过压、过流等预警系统。

14.7. Battery Pack Assembly (电池包组装)

14.7.1. Prohibition of usage of Damaged Cell (禁止使用损坏的电芯)

The cell should be inspected visually before battery assembly.

电池包装配前应目视检查每个电芯。

The cell should not be used if sleeve-damage, can-distortion and/or electrolyte-smell is detected.

如果电芯套管损坏、钢壳变形或有电解液气味，则电芯不能继续使用。

14.7.2. Connector Handing (连接片焊接)

Excessive force on the cells' terminal should be avoided when external strip connector is welded.

焊接连接片时，应避免对两端施加过大的力。

14.7.3. Transportation (运输)

If the cell is necessary to be transported to such as the battery manufacturer, careful precautions should be taken to avoid damage of cell.

如果电芯需要运输到电池厂家，应采取必要的预防措施，以避免电芯损坏。

14.8. Others (其他)

14.8.1. Disassembly (拆解)

The cell should not be dismantled from the battery pack.

电芯不应从电池组中拆下。

Internal short-circuit caused by disassembly may lead to heat generation and/or venting.

拆卸引起的内部短路可能导致电芯发热或产气。

If liquid leaking from the battery gets into your eyes, don't rub your eyes and wash them with clean water and go to see a doctor immediately

如果电池泄露的液体进入你的眼睛，不要揉眼睛，请用清水清洗，并立即去看医生。

Model	EVE-INR18650/29V	Spec. No.	PBRI-INR18650/29V-D06-13	Version No.	A
-------	------------------	-----------	--------------------------	-------------	---

14.8.2. Short-circuiting (短路)

Short-circuit results in very high current which leads to heat generation.

短路会产生非常大的电流，从而导致发热。

An appropriate circuitry should be employed to protect accidental short-circuiting.

使用时应采用正确的线路，防止意外短路。

14.8.3. Incineration (焚烧)

Incinerating and disposing of the cell in fire are strictly prohibited, because it may cause rupture and explosion.

严禁用火焚烧和处置电芯，因为可能会引起电芯破裂和爆炸。

14.8.4. Immersion (浸泡)

Soaking the cell in water is strictly prohibited, because it may cause corrosion and leakage of components to be damaged to functions.

严禁将电芯浸泡在水中，否则会引起电芯的腐蚀和漏液，使电芯的功能受损。

14.8.5. Mixing use (混合使用)

Different types of cell, or same types but different cell manufacturer shall not be used, which may lead to cell imbalance, cell rupture or damage to system due to the different characteristics of cell.

使用不同类型的电芯，或不同的电芯制造商同种类型的电芯，由于电芯的不同特性，可能导致电芯不平衡，电芯破裂或系统损坏。

14.8.6. Battery Exchange (电芯更换)

Although the cell contains no environmentally hazardous component, such as lead or cadmium, the battery shall be disposed according to the local regulations when it is disposed.

电芯不含铅、镉等有害环境成分，但处理时应按当地法规处理。

The cell should be disposed with a discharged state to avoid heat generation by an inadvertent short-circuit.

电芯应在低电量状态处理，避免因意外短路而产生热量。

14.8.7. Caution (注意事项)

The battery used in this device may present a risk of fire or chemical burn if mistreated.

如果电芯使用不当，可能会导致火灾或化学烧伤。

Do not disassemble, expose to heat above 100°C or incinerate it.

禁止拆解电芯，在 100°C 以上高温加热或火烧电芯。

Do not expose the cell to extreme heat or flame.

不要将电芯暴露在极热的环境或火焰中。

Do not short circuit, over-charge or over-discharge the cell.

不要将电芯短路、过充或过放。

Model	EVE-INR18650/29V	Spec. No.	PBRI-INR18650/29V-D06-13	Version No.	A
-------	------------------	-----------	--------------------------	-------------	---

Do not subject the cell to strong mechanical shocks.

不要使电芯承受过重的机械冲击。

Do not immerse the cell in water or sea water, or get it wet.

不要将电芯浸入海水或水中，或者使其吸湿。

Do not reverse the polarity of the cell for any reason.

不要颠倒电芯的正负极。

Do not disassemble or modify the cell.

不要拆卸或修整电芯。

Do not handle or store with metallic like necklaces, coins or hairpins, etc.

不要和项链、硬币或发夹等金属物品放置在一起。

Do not use the cell with conspicuous damage or deformation.

不要使电芯受到明显的损害或变形。

Do not connect cell to the plug socket or car-cigarette-plug.

不要将电芯与插座连接。

Do not make the direct soldering onto a cell.

不要直接焊接电芯。

Do not touch a leaked cell directly.

不要直接接触漏液的电芯。

Do not use Lithium-ion cell in mixture.

不要将锂离子电芯混合使用。

Do not use or leave the cell under the blazing sun (or in heated car by sunshine).

不要将电芯放置在太阳光直射的地方（或在太阳底下暴晒的汽车里）。

Keep cell away from children.

将电芯放置在远离儿童的地方。

Do not drive a nail into the cell, strike it by hammer or tread it.

不要针刺、捶打或践踏电芯。

Replace battery with those of EVE only.

只能更换 EVE 的电芯。

15. Others (其他)

15.1.Storage for a Long Time (长期存放)

If the cell is kept for a long time (3 months or more), it is strongly recommended that the cell is performed one cycle, the voltage of the cell is recommended from 3.50V to 3.80V, the environment should be low-temperature

亿纬保密信息，未经允许不得扩散

Model	EVE-INR18650/29V	Spec. No.	PBRI-INR18650/29V-D06-13	Version No.	A
-------	------------------	-----------	--------------------------	-------------	---

(normally 0~25°C), dry and no corrosive gas.

如果电芯存放时间较长(3 个月或以上), 强烈建议电芯进行一次循环, 电芯电压建议 3.50V 到 3.80V, 环境应低温(通常为 0~25°C)、干燥且无腐蚀性气体。

15.2.Others (其他)

Any other matters not covered under this specification shall be separately negotiated and confirmed by both parties.

任何本规格书中未提及的事项, 须经过双方协商确定。

16. Consultation (联系方式)

Address: EVE Energy Co., Ltd.-EVE Industrial Park on No.38, Huifeng 7th Road, Zhongkai Hi-Tech Zone, Huizhou.

Tel No.: 86-752-2630809

Fax No.: 86-752-2606033

Website: [Http://www.evebattery.com.cn](http://www.evebattery.com.cn)

如有疑问, 请按以下方式咨询:

地址: 中国广东省惠州市仲恺高新区惠风七路 38 号惠州亿纬锂能股份有限公司

电话: 86-752-2630809

传真: 86-752-2606033

网址: [Http://www.evebattery.com.cn](http://www.evebattery.com.cn)

Model	EVE-INR18650/29V	Spec. No.	PBRI-INR18650/29V-D06-13	Version No.	A
-------	------------------	-----------	--------------------------	-------------	---

Attachment (附件) :

Fig 1 (图 1) :

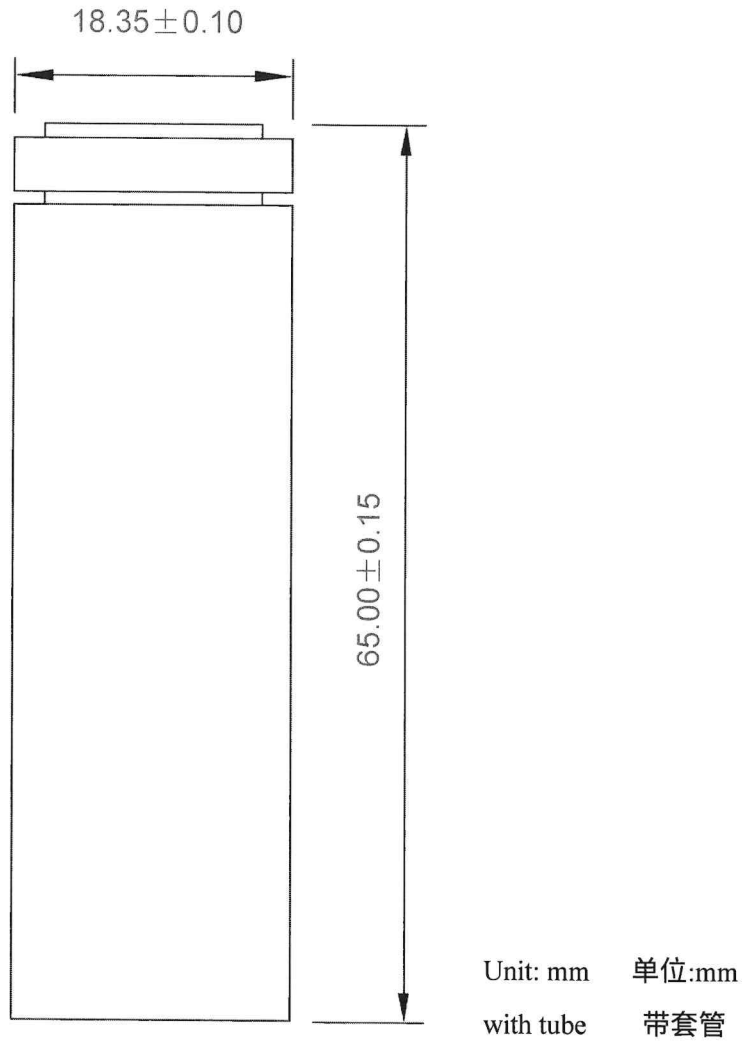

Fig. 1. Outline Dimensions of INR18650/29V

图 1. INR18650/29V 外形尺寸

Model	EVE-INR18650/29V	Spec. No.	PBRI-INR18650/29V-D06-13	Version No.	A
-------	------------------	-----------	--------------------------	-------------	---

Attachment (附件) :

Fig 2 (图 2) :

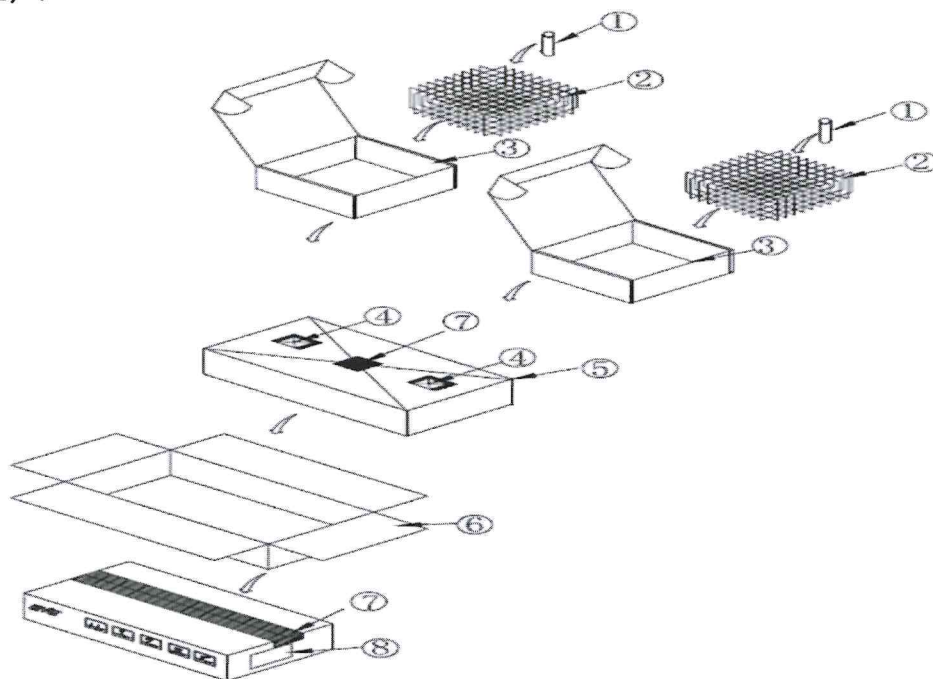

NO.	Part Name 部件名称	Material 材料	Q'Ty 单位
1	Cell 电芯	型号 INR18650/29V	200 pcs/box
2	Packing Bulkhead 刀卡	Cardboard 卡纸	36 pcs/box
3	Box(Packing Case In) 内箱	Corrugated Board 瓦楞纸箱	2 pcs/box
4	Silicagel 干燥剂	Si 硅	2 pcs/box
5	Bag PE/POF 防水袋/热缩膜	PE/POF 聚乙烯/多层共挤聚烯烃热收缩膜	1 pcs/box
6	Box(Packing Case Out) 外箱	corrugated board 瓦楞纸箱	1 pcs/box
7	Tape 胶带	PE 聚乙烯	0.01 rol/box
8	Product Label 产品标签	Art Paper 铜版纸	1 pcs/box